



# IPDTechBulletin

The Standard for Quality, Innovation, Service and Support Since 1955

April 23, 2017

IPDTB-0008

## **CRITICAL INFORMATION – CAT® 3500 SERIES DIESEL VALVETRAIN UPDATES**

The Cat® 3500 Series diesel valvetrain has had multiple updates. Using compatible valvetrain components is **critical** to the service life of the engine.

### Floating Bridges:

- The update from the “doweled” valve bridge to the “float” bridges is common.
- On older style assemblies, the valve bridges rode on a dowel that was pressed into the cylinder head.
- Newer style floating bridges no longer require a dowel to ride on and eliminate the bridge adjustment. This update also introduced ½” diameter stem exhaust valves and required different Valve Seats, Valve Springs, Valve Guides, Rotators, Spring Washers & Valve Stem Seals.
- Since the release of the “floating” valves bridges there have been additional updates depending on specific applications.

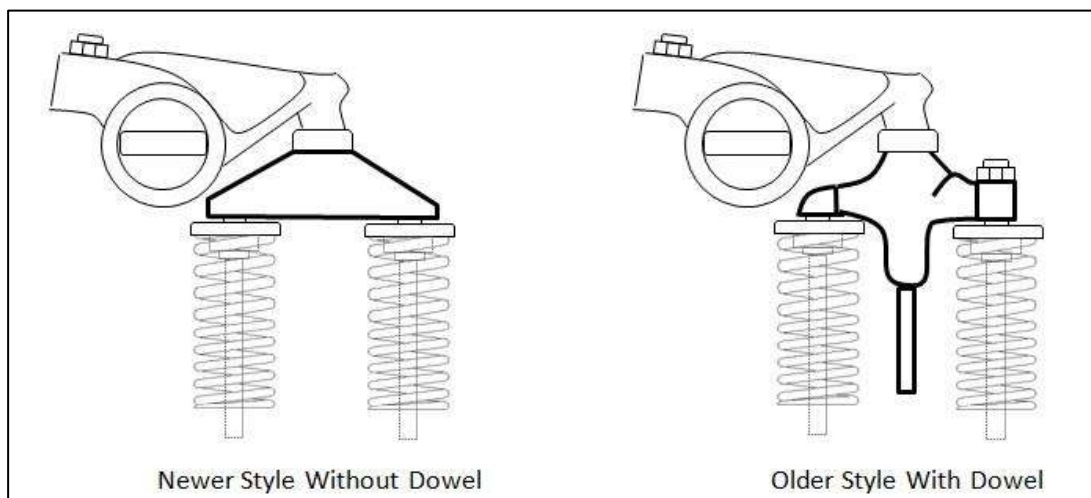

All information is believed to be accurate at time of printing. No guarantee of accuracy is made by IPD. Please consult your service and parts manual for detailed information. This is intended as a warning only, not a specification. All manufacturers' names, numbers, symbols and descriptions are for reference only. It is not implied that any part is the product of the manufacturer. Caterpillar® and Cat® are registered trademarks of Caterpillar, Inc.



# IPDTechBulletin

The Standard for Quality, Innovation, Service and Support Since 1955

## NOTES:

There have been multiple component updates in these valvetrain components. Some of the changes have been global changes that updated parts everywhere they were used, while others have been specific to select machines or applications. IPD deals with rebuilders and parts suppliers around the world, some are very technical and make their own decisions as to which updates or combination of components work best in their situations. Others consistently want only the latest designs. And still, there are those that have had good experiences with what they've been using and want to continue using what works best for them.

This tech bulletin is not intended to be your only resource for parts reference, but rather to help explain some of the changes and make you aware of possible incompatibility issues. Please contact IPD for more specific application information, or reference IPDNet.

To help illustrate the complexity of the parts compatibility for the 3500 valvetrain, attached are lists of some compatible parts groups that we have found.

**These lists are for reference only! They are not intended to replace actual part number research or updates for your specific application.**

### 3500 Series Engine Valvetrain - Compatibility Parts Groupings

These lists are for reference only! They are not intended to replace actual part number research or updates for your specific application.

Era	Part	Description
<b>E A R L Y</b>	2102542	Valve, Intake 3/8" Stem 20°
	1219835	Valve, Exhaust 3/8" 45°
	1219839	Valve, Exhaust 3/8 Stem 45°
	1339306	Valve Guide (Intake & Exhaust) 3/8"
	7N1903	Inner Spring, Counter Clockwise Coil, Pink & Blue Stripes
	7N1904	Outer Spring, Clockwise Coil, Pink & Blue Stripes
	1976999	RotoCoil (Intake & Exhaust)
	2A4429	Lock (Intake & Exhaust)
	1302608	Insert, Exhaust 30°
	1302607	Insert, Intake 20°
	1302608	Insert, Exhaust 45°
	1376856	Seal
	2W2662	Spring, Seat
	7N1902	Dowel
	1294181	Bridge
<b>M I D</b>	2102542	Valve, Intake 3/8" Stem 20°
	2102529	Valve, Exhaust 3/8 Stem
	1339306	Valve Guide (Intake & Exhaust) 3/8"
	7N1903	Inner Spring, Counter Clockwise Coil, Pink & Blue Stripes
	7N1904	Outer Spring, Clockwise Coil, Pink & Blue Stripes
	1976999	RotoCoil (Intake & Exhaust)
	2A4429	Lock (Intake & Exhaust)
	1302607	Insert, Intake 20°
	1189491	Insert, Exhaust 45°
	1376856	Seal
	2W2662	Spring, Seat
	7N1902	Dowel
	1294181	Bridge
	7E4609	Valve, Intake 3/8" 30°
	1219839	Valve, Exhaust 3/8 Stem 45°
9Y1847	Valve Guide (Intake & Exhaust) 3/8"	
7N1903	Inner Spring, Counter Clockwise Coil, Pink & Blue Stripes	
7N1904	Outer Spring, Clockwise Coil, Pink & Blue Stripes	
1976999	RotoCoil (Intake & Exhaust)	
2A4429	Lock (Intake & Exhaust)	
7E5862	Insert, Intake 30°	
1W1801	Insert, Exhaust 30°	
1376856	Seal	
2W2662	Spring, Seat	
7N1902	Dowel	
1294181	Bridge	

Continued on next page



Era	Part	Description	
M I D	7E4609	Valve (Intake & Exhaust) 3/8" 30°	
	9Y1847	Valve Guide (Intake & Exhaust) 3/8"	
	7N1903	Inner Spring, Counter Clockwise Coil, Pink & Blue Stripes	
	7N1904	Outer Spring, Clockwise Coil, Pink & Blue Stripes	
	1976999	RotoCoil (Intake & Exhaust)	
	2A4429	Lock (Intake & Exhaust)	
	7E5862	Insert, Intake 30°	
	1W1801	Insert, Exhaust 30°	
	1376856	Seal	
	2W2662	Spring, Seat	
	7N1902	Dowel	
	1294181	Bridge	
	<b>Separator</b>		
		2102542	Valve, Intake 3/8" Stem 20°
		1944897	Valve, Exhaust 1/2" Stem 45°
		1339306	Valve Guide 3/8"
		1976995	Valve Guide 1/2"
		1944902	Inner Spring, Clockwise Coil, Green & Orange Stripes
		2816157	Outer Spring, Counter Clockwise Coil, White Stripe
		1977062	RotoCoil (Intake) 3/8"
		2348777	RotoCoil (Intake & Exhaust)...See <b>"Note A"</b> below
		1977063	RotoCoil (Exhaust) 1/2"
		2A4429	Lock (Intake) 3/8"
		1977055	Lock (Exhaust) 1/2"
		1302607	Insert, Intake 20°
		1302608	Insert, Exhaust 45°
	1977006	Seal 3/8"	
	3090962	Washer	
	2390689	Dowel Note B	
	2657537	Bridge (Intake) Floating	
	2657538	Bridge (Exhaust) Floating	
	<b>Note A:</b>	Only Required On 3500 Locomotive. 2348777 is serviced by 1977063 RotoCoil, & 2348776 Shield	
	<b>Note B:</b>	Only required on 3500MUI. Because of the force applied to the fuel injector by the rack, the 2390689 dowel is required for orientation of the fuel injector	
<b>Separator</b>			
L A T E		2102542	Valve, Intake 3/8" Stem 20°
		1944897	Valve, Exhaust 1/2" Stem 45°
		1339306	Valve Guide 3/8"
		1976995	Valve Guide 1/2"
		3165977*	Inner Spring, Counter Clockwise Coil, Yellow Stripe
		3165976*	Outer Spring, Clockwise Coil, Yellow Stripe
		3165978*	RotoCoil (Intake)
		3165979*	RotoCoil (Exhaust)
		2A4429	Lock (Intake) 3/8"
		1977055	Lock (Exhaust) 1/2"
		1302607	Insert, Intake 20°
		1302608	Insert, Exhaust 45°
		3165980*	Seal
		3165981*	Washer (Exhaust)
		2657537	Bridge (Intake) Floating
		2657538	Bridge (Exhaust) Floating
		<b>*Note:</b>	These parts must be used in conjunction with each other. Mixing with former designs will cause engine damage and/or failure