

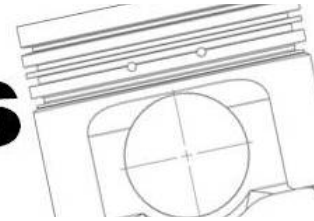

# IPDNews



January-February 2017

## IPD Parts for Caterpillar® C27

IPD engine kits for C27 applications feature **IPDSteel®** friction welded pistons. This innovative piston design is exclusively available in the aftermarket only from IPD. All **IPDSteel** pistons are manufactured by IPD in Torrance, California (USA).



IPD offers these kits with your choice of two cylinder liner designs, an original style design or IPD's optional "crevice seal" cylinder liner (available exclusively from IPD). IPD's crevice seal design provides a more secure fitment, reducing liner movement and extending the life of the o-rings and the lower bore in the block.

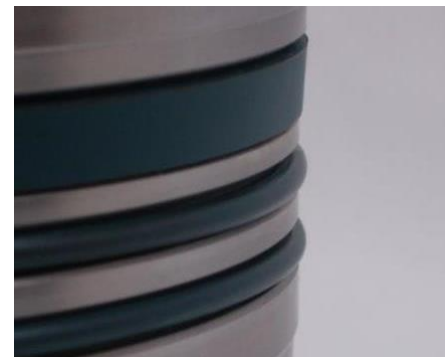

IPD parts kits for C27 fit a wide range of applications, including:

- **D10T tractors**
- **773G/F & 775G off-highway trucks**
- **844H dozers**
- **990H/K loaders**
- **Generators**



[CLICK HERE](#) for product bulletin and line card

---

## Technical Bulletin - Caterpillar® C27 Pistons

Caterpillar discontinued the one-piece C27 piston (#2477792), now updated to (#3767362) a stronger friction welded design. IPD also offers the updated style friction-welded piston, details as follows:



*Previous C27 1pc piston design*



*Updated C27 welded piston design*

- Updated **IPDSteel®** friction welded piston for C27 applications exclusively offered only by IPD in the aftermarket
- **IPDSteel** pistons for C27 engines are the only "correct specification" alternative to dealer parts
- All **IPDSteel** pistons are manufactured at IPD headquarters in Torrance, California (USA)

IPD is the preferred dealer alternative in the aftermarket for the most updated engine parts available. Contact IPD and begin saving today!

[CLICK HERE](#) for technical bulletin

---

## Technical Information - Friction Welded Piston Grooves

Please be advised that on friction welded pistons, 4 grooves are visible, but only the top 3 are designated piston ring grooves. Please reference the bulletin via the link below for more information.

[CLICK HERE](#) for details

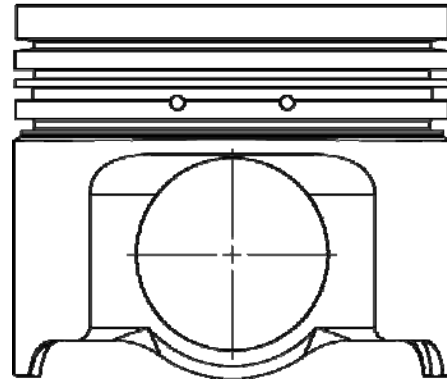

IPDSteel Welded Piston Illustration

---

## IPD WINS AWARD

IPD was recently awarded an **Innovators in Infrastructure Award** for 2016 by Build



Magazine. This award recognizes the standout firms in the arena..."the exclusive shortlist of the best-of-the-best when it comes to the infrastructure sector."

## About IPD

Since 1955, IPD has focused on helping equipment owners save money without risk to reliability. IPD continues to build on over 60 years of manufacturing experience with Quality Products, Technical Innovation, and Superior Customer Service and Support. IPD's product line includes diesel and spark-ignited gas engine parts for Caterpillar®, Cummins®, Detroit Diesel®, Waukesha®, and Volvo® applications.

*All manufacturers' names, numbers, symbols and descriptions are for reference only. It is not implied that any part is the product of the manufacturer. Cat®, Caterpillar®, Cummins®, Detroit™, Detroit Diesel®, Volvo®, & Waukesha® are trademarks of their respective owners.*

**[sales@ipdparts.com](mailto:sales@ipdparts.com) | [www.ipdparts.com](http://www.ipdparts.com)**

Manufacturer names shown are for reference only, and are trademarks of their respective owners.